Integrated CMOS Image Sensor with Digital Output and Timing Controller (352 x 288 Resolution)

Technical Data

HDCS-1000 (Color)
HDCS-1100 (Monochrome)

Description

A CMOS active pixel sensor (APS) array, available in both color and monochrome, containing an array of 352 x 288 pixels. This product offers excellent image quality with low power consumption, low dark current, high sensitivity and anti-blooming characteristics. High temperature tolerant color filter array enables machine solderability. Operating from a single bias voltage, this sensor simplifies overall system design.

Features

- CIF (352 x 288 pixels) array size in two options. Color or monochrome versions available
- Random access and windowing capability to zoom to any sized window on 4 x 4 pixel boundaries
- Panning capability to any location within the sensor array
- Video rates up to 45 frames per second for CIF window size
- 4:1 sub-sampling capability of viewing window, providing up to 162 frames per second
- Still image capability
- Mechanical shutter and flash trigger
- Accumulation mode to aid in determining proper exposure time
- Low power/standby modes
- Machine solderable, high temperature tolerant color filter array
- Two 10-bit internal successive-approximation ADCs
- Automatic subtraction of column fixed pattern noise
- Color array using RGB Bayer filter pattern
- Integrated timing controller simplifying system design
- Digital output via 10-bit synchronous parallel interface
- Programmable features include: window size, integration time, gain control (separate for red, green and blue), data rate, interface timing, interrupt control, operation modes, selection of 8 or 10 bit output, drive level of output pads, access to status signals via a synchronous serial or asynchronous UART interface



Typical Applications

- Video conferencing camera
- Digital still camera
- Surveillance and security video camera
- Automotive
- Machine vision system
- Biometric security system (e.g., fingerprint recognition)
- Toys

Typical Electrical Specifications

Pixel Size	7.8 x 7.8 μm
Maximum Clock Rate	25 MHz from externally supplied clock source
A/D Dynamic Range	60 dB
Pixel Signal-to-Noise Ratio (SNR)	66 dB
Noise (Equivalent electrons) kTC	36 electrons
Dark Current ^[1]	0.1 nA/cm ² @ 22°C ambient
Sensitivity ^[2]	1.3 V/(Lux-sec @ 550 nm)
Peak Quantum Efficiency ^[1, 2]	21%
Saturation	1.3 V
Full Well Capacity	65,000 electrons
Conversion Gain ^[2]	16 $\mu\text{V}/\text{electron}$
Programmable Gain Range	1 – 40 (255 increments)
Fill Factor	42%
Exposure Control	0.5 μs – 4 s in 0.5 μs steps
Package	44 pin gull wing optical PQFP
Supply Voltage	3.3 V, -5/+10%
Power Consumption	200 mW max operating; 3.3 mW max standby
Operating Temperature	-5 to 65°C

Notes:

1. Specified over complete pixel
2. Measured at unity gain

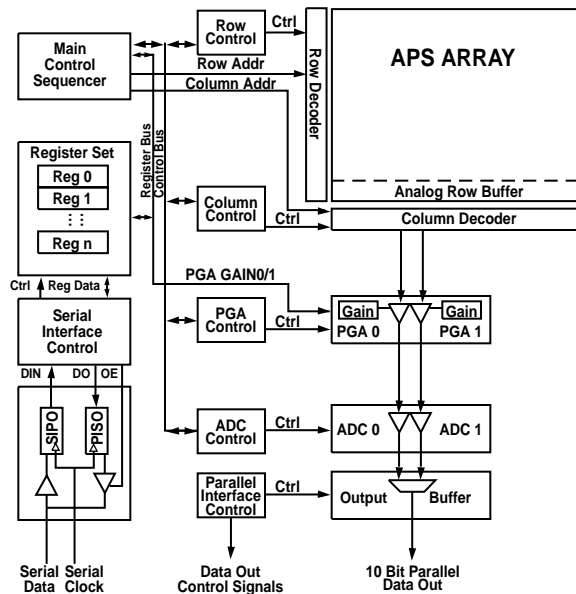

www.hp.com/go/imagingelectronics

For technical assistance or the location of your nearest Hewlett-Packard sales office, distributor or representative call:

Americas/Canada: 1-800-235-0312 or 408-654-8675

Far East/Australasia: Call your local HP sales office.

Japan: (81 3) 3335-8152

Europe: Call your local HP sales office.

Data subject to change.
Copyright © 1998 Hewlett-Packard Co.
Obsoletes 5968-2422E

5968-3057E (11/98)

Block Diagram—Sensor Architecture